



CORVEX
P u m p s
www.corvexpumps.com

LINEA SP

SLURRIES PUMPS



CONTENTS

About Us	3
WSA (R) - Mill Circuit Sever Duty Slurry Pump	4
WX(R)/WXA(R) - Heavy Duty Slurry Pump	5
WL(R) - Low to Medium Head Heavy Duty Slurry Pump	6
WMP - Heavy Duty Slurry Pump	7
WXH - High Head Heavy Duty Slurry Pump	8
VC(R)/VCS & VCH - Heavy Duty Slurry Pump	9
WG(H) - Gravel & Dredge Pump	10
WSH - Heavy Duty Slurry Pump	11
WXF (R)/WLF (R) & WAF - Froth Pump	12
WDL (R) - Fuel & Gas Desulfurization Slurry Pump	13
SPS - Submerged Slurry Pump	14
SPH & SPL - Medium to Heavy Duty High Head Slurry Pump	15
WXS - Heavy Duty Non - clogging Pump	16

SP Series (Slurry Pumps)

► ABOUT US

CORVEX PUMPS Co.,Ltd., it is a mining equipment manufacturing and service group which possesses a complete R&D team. Serving a global market with worldwide distribution and overseas branches in South Africa, Peru and Australia, CORVEX PUMPS specializes in handling the toughest and most abrasive applications. It is striving for the best in product reliability, availability, and value as well as customer satisfaction.

Through years of research and product development, we have developed a comprehensive range of 14 pump series covering over 158 models that make up our slurry pump range. With a capacity of over 3500 pump sets per annum. Currently the largest pump we manufacture is 760mm mill circuit slurry pump with 760mm (discharge ID). Up to today CORVEX PUMPS has been installed in many of the world's top mining houses and has gained a well-deserved reputation for quality, reliability and cost saving among our customers worldwide.



- Tailed Pumping Solutions
- Highly Engineered Equipments
- Aftermarket Care
- OEM Wear Parts
- Global Sales and Service Support

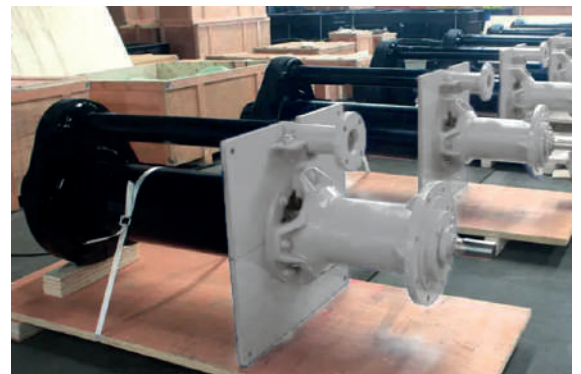

WSA (R) - Mill Circuit Sever Duty Slurry Pump

The WSA(R) pumps are particularly designed to operate in more aggressive wear applications, easily handle large particles in dense abrasive pulps, and perfectly combine strength, durability, hydraulics, and construction materials.

WSA(R) pumps are the best choice for applications ranging from the most abrasive grinding discharge to crushed ore pumping. Furthermore, all grinding processes can be covered, when operated in conjunction with the WX pump.



Discharge size: 5"~34" / Capacities to: 22000 m³/hr / Heads to: 55 m

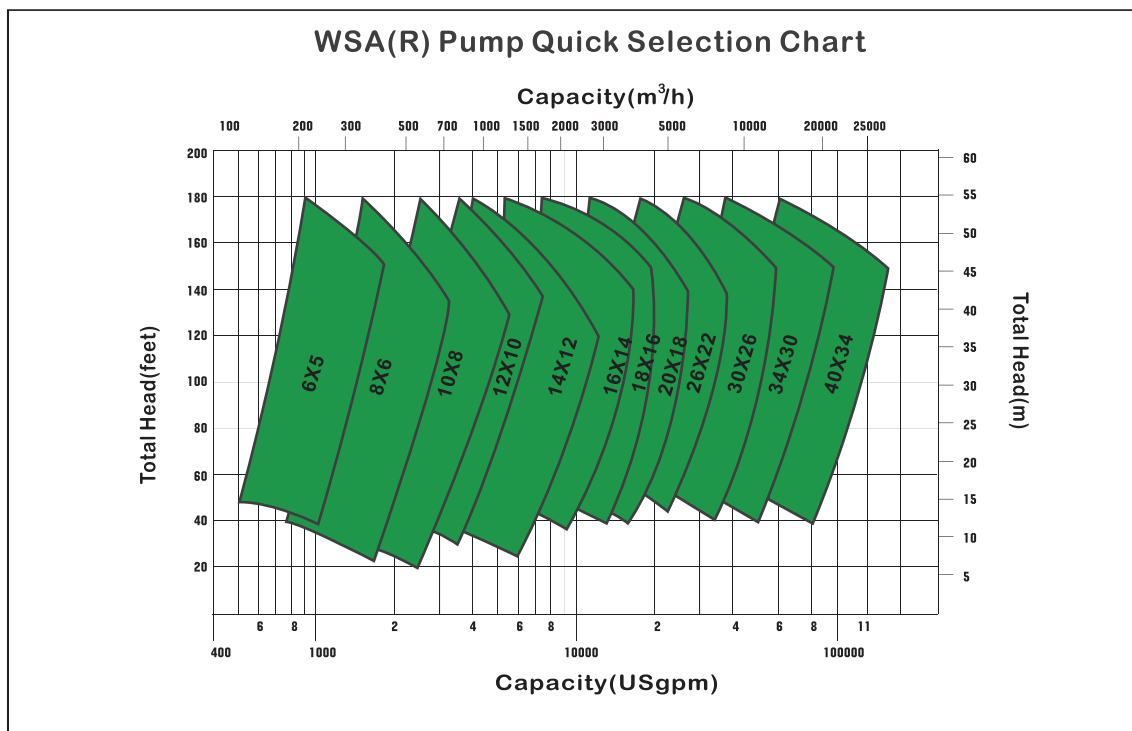

Pump Features

Single stage, single suction, overhang shaft, centrifugal, double casing horizontal pump

Material Ceramics - Elastomeric linings with alloy impellers provide longer life, particularly in cyclone feed circuits and more complex screen unloading services

Passage - Large diameter impellers with a wide passage design assures lower running speeds which achieve longer wear life and reduces maintenance.

Bearings - A short and large diameter shaft together with quality heavy duty roller bearings reduce shaft bending, pump vibration and overheating whilst pump is in operation.

Adjustable impeller clearance - The clearance between the impeller and the throat bush can be adjusted to assure the pumps run at their best efficiencies.

Flanges - Flange sizes are in accord with standard ASME/ANSI B16.5 and 16.47 or be customized regarding specific requirement

SP Series (Slurry Pumps)

WX(R)/WXA(R) - Heavy Duty Slurry Pump

WX(R) & WXA(R) hard metal/rubber heavy duty slurry pumps are designed for the most difficult pumping applications for highly abrasive, high density or corrosive slurries. Extra thick sections at the critical wear points and superior Impeller structure ensures improved performance with extended wear and minimised maintenance, thus improving cost of ownership. Rubber lined pumps expand applications to chemical products handling, several different rubber options are available to meet different application requirements. Best fitted in aggressive applications, like mill discharge and tailing transfer.

WXA(R) pumps are improved version of WX(R) pumps, with an adjustable wear plate seated in at the Throat bush. It can be adjusted while the pump is running.



WXA-Adjustable Impeller Clearance

Discharge size: 1"~18" / Capacities to: 5400m³/hr / Heads to: 68m

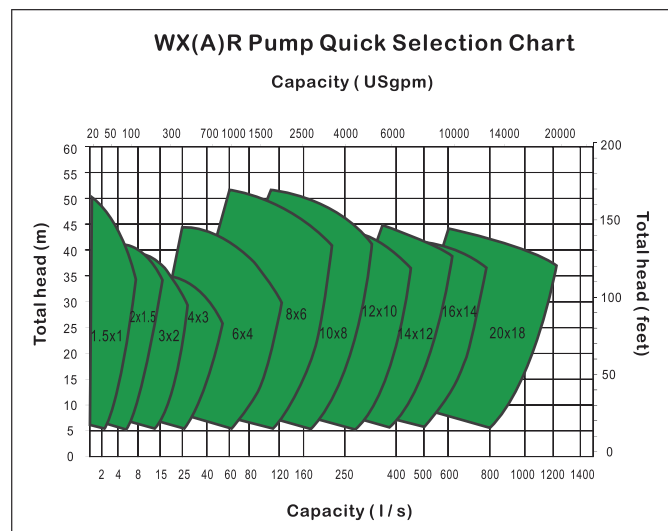
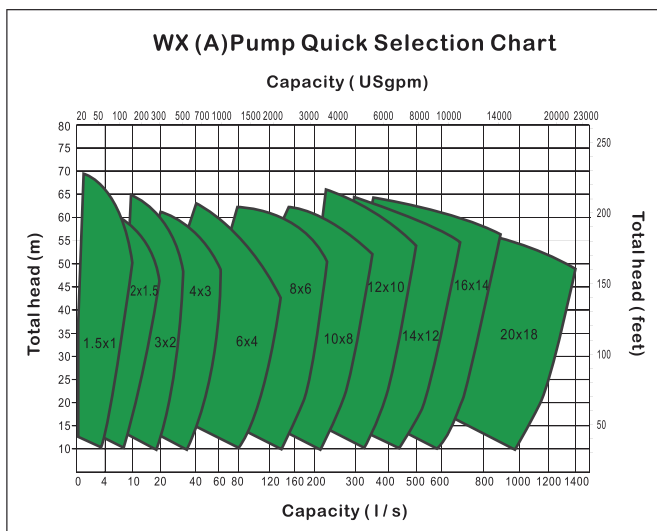

Pump Features

Single stage, single suction, overhang shaft, centrifugal, double casing horizontal pump

Material:

Casing are made of ductile Iron, ribs help casing to withstand higher pressures.

Wet Ends - Impellers, liners, volutes are made of high-chrome alloy or rubber or polyurethane or ceramics, to resist wear, corrosion or impact, parts made of metal or rubber are interchangeable.

Shaft sleeve: Ceramic, tungsten carbide or other hard material are optional for coating, to increase wear resistance.

Bearing Assembly - Grease lubrication and oil lubrication are optional depending on the usage.

Seal options - Gland seal, expeller(centrifugal or dynamic) seal and mechanical seal are optional to fit different application.

Parts design:

Impeller-Multiple impeller types for diverse applications to get best performance: High efficiency, high efficiency with lower NPSHr, large particle, enhanced performance, flow reducer, recessed eyes are available.

Liners-Different types to match different impellers.

WL(R) - Low to Medium Head Heavy Duty Slurry Pump

WL (R) light to medium duty slurry pumps are designed for continuous slurry handling applications where a large flow at a low to medium head is required. Especially for medium abrasive and lower solids concentrations applications. Similar in structure to WX pump, WL(R)pumps are smaller sized and relatively economical to handle mild slurries



Discharge size: 20–650mm / Capacities to: 10260m³/hr / Heads to: 63m

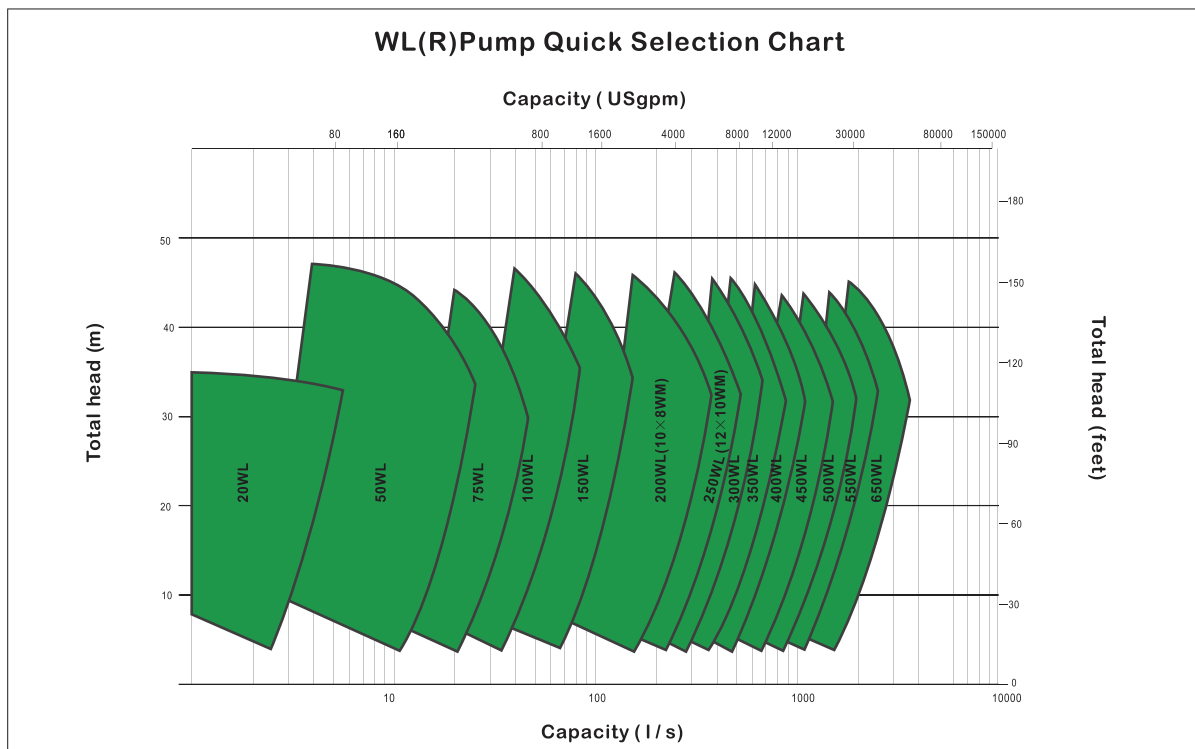

Pump Features

Single stage, single suction, overhung shaft, centrifugal, double casing horizontal pump

Material:

Casing-Made of ductile Iron, ribs help casing to stand high pressure.

Wet Ends-Impellers, liners, volutes are made of high-chrome alloy or rubber or ceramics, to resist abrasion, corrosion, impact or erosion, parts made of metal or rubber are interchangeable.

Bearing Assembly - Grease lubrication and oil lubrication are optional depending on the usage.

Seal options - Gland seal, expeller(centrifugal or dynamic) seal and mechanical seal are optional to fit different application.

Parts design:

Compare with WX(R), WL(R)pumps are smaller sized, more economical when dealing with mild media.

SP Series (Slurry Pumps)

WMP - Heavy Duty Slurry Pump

WMP medium abrasion slurry pumps are designed for the most difficult pumping applications for highly abrasive, high density or erosive slurries.

Extra thick sections at wear point and perfect impeller structure ensures satisfactory performance with long life and needs minimum maintenance requirements.



Discharge size: 2"~10" / Capacities to: 1800m³/hr / Heads to: 66m

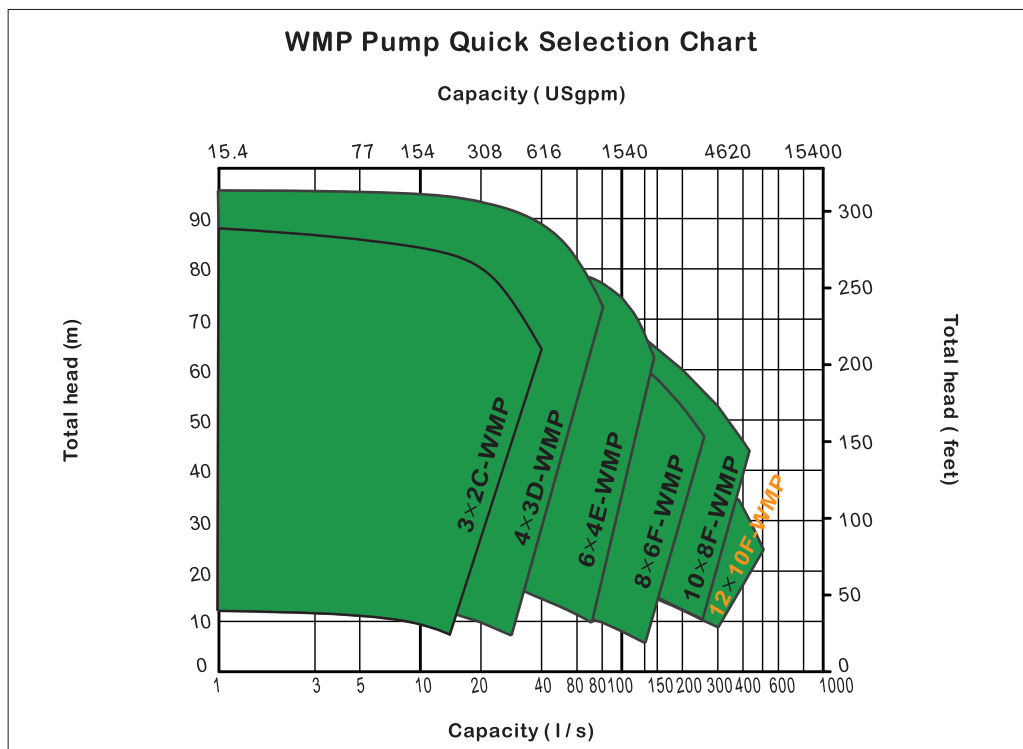

Pump Features

Single stage, single suction, overhang shaft, centrifugal, single casing horizontal pump

Material: Casing, impeller, plates are made of high chrome alloy or ceramics, to resist abrasion, corrosion and impact.

Shaft Sleeve: Ceramic, tungsten carbide or other hard material are optional for coating, to increase wear resistance.

Bearing Assembly - Grease lubrication are optional depending on the usage.

Seals options - Gland seal, expeller(centrifugal or dynamic) seal and mechanical seal are optional to fit different application.

Part design

Impeller - with multiple impeller types, for diverse applications to get best performance.

High efficiency with lower NPSHr, large particle handling, enhanced performance, increased durability.

Recessed eyes are available.

WXH - High Head Heavy Duty Slurry Pump

The WXH pumps are designed to produce high staged discharge head at high pressure and have been commonly used for long distance transport lines. They are frequently used on lines where multiple pumps could operate in series, thus reducing the number of pumps.



Discharge size: 1"~6" / Capacities to: 1152m³/hr / Heads to: 98m

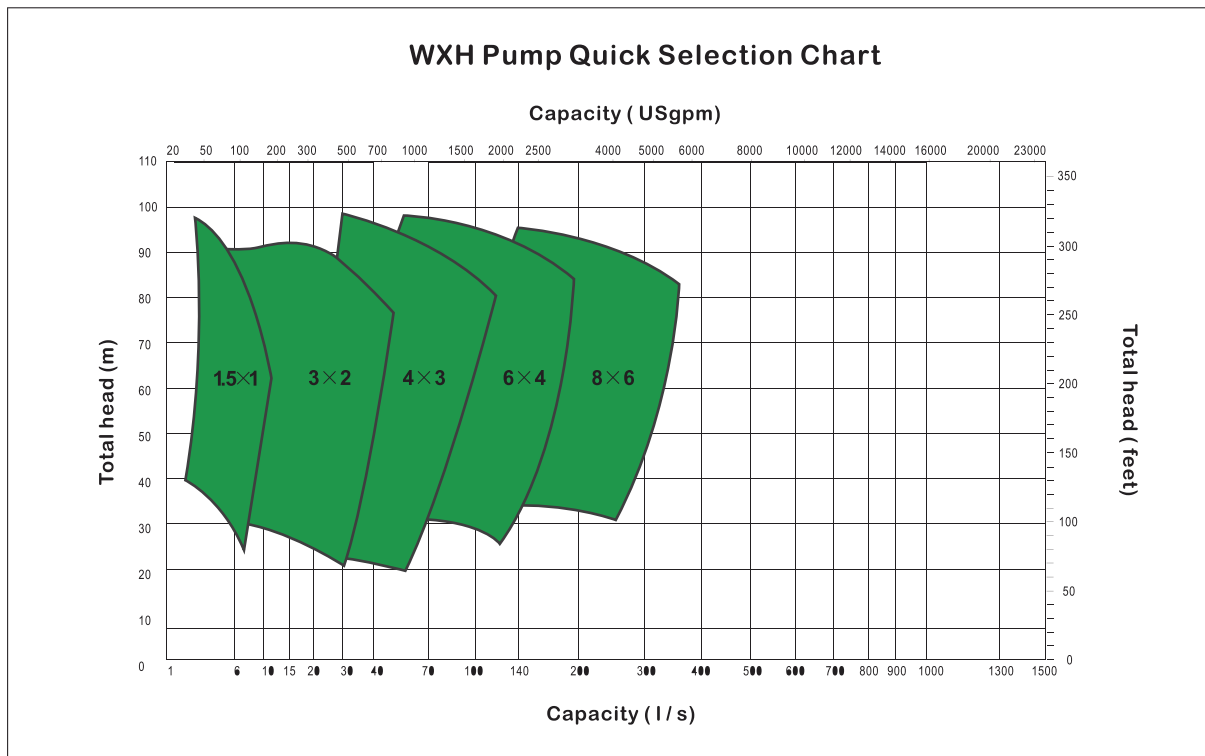

Pump Features

Single stage, single suction, overhang shaft, centrifugal, double casing horizontal pump

Material:

Casing are made of ductile iron; bolstered ribs help casing withstand high pressures.

Wet Ends - Impellers, liners, volutes are made of high-chrome alloy or ceramics to resist wear, corrosion, and Impact.

Bearing Assembly - Grease lubrication and oil lubrication are optional depending on the usage.

Seal options - Gland seal, expeller(centrifugal or dynamic) seal, mechanical seal is optional to accommodate different application.

Parts design.

Impeller has a large diameter, low turning speed, with wide veins and recessed vanes help lower internal velocity and extend wear life.

SP Series (Slurry Pumps)

VC(R)/VCS & VCH - Heavy Duty Slurry Pump

VC(R) /VCS slurry pumps are designed for handling abrasive and corrosive slurries, whilst submerged in sumps or pit.

The pump has no shaft seal, easy to maintenance and cost of ownership is reduced.

VCH slurry pumps are designed for long distance transport applications. No submerged bearing or packing. High volume, double suction design with relatively high head.

Hard metal and rubber parts are optional for different applications and are interchangeable. Suitable for most applications where sump slurry pumps are needed.

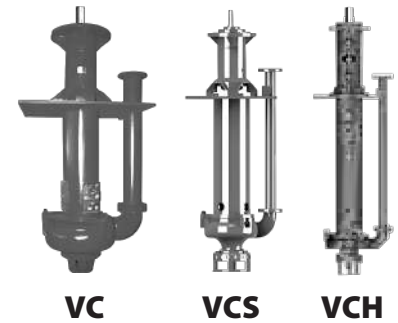

VC

VCS

VCH

Discharge size: 40~250mm / Capacities to: 1090m³/hr / Heads to: 60m

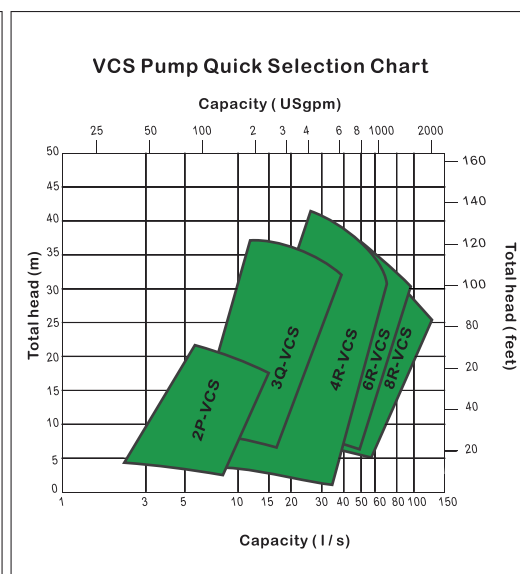
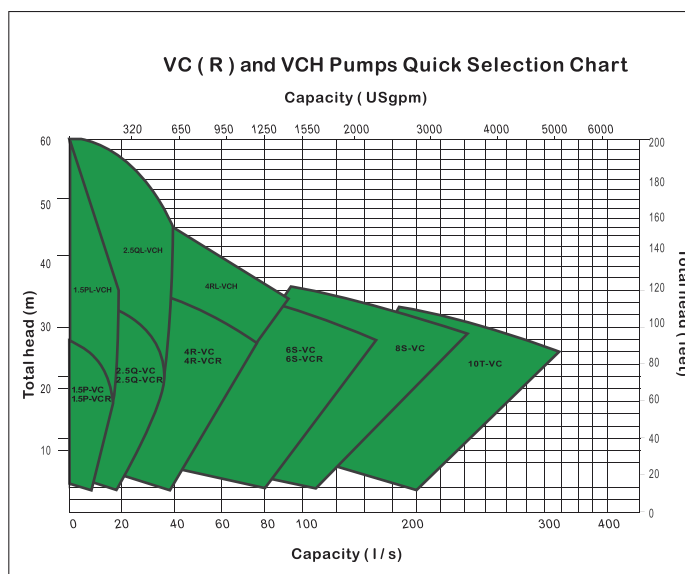

Pump Features

Single stage, single suction, overhang shaft, centrifugal, single casing structure vertical pump

Material:

Casings, impellers, liners are made of high-chrome alloy or rubber or ceramics, to resist wear, corrosion or impact, parts made of metal or rubber are interchangeable.

* For VCS, only metal material is optional

Seal options - No shaft seal, free of shaft sealing problems.

Structure - No impeller clearance adjustment is needed, easy to maintain and operate.

Bearing Assembly - Grease lubricated, easy to maintenance.

With a heavy-duty bearing assembly, ensures the stability and smooth running of the pump.

With large particle handling capabilities.

Has "Dry Run" capability.

VC(R) - Standard impellers

Inlet - The bottom and top inlet design allows for no priming

Strainer - Reduce blockage rate.

Impeller - Double suction vanes reduce the axial load.

Suction pipe - could be fixed to draw away the high concentrated slurry deposited on the bottom of pit.

There is also an agitator option in hi-chrome only.

VCS- Non-clogging Sump Pumps with recessed impellers

The recessed impeller and the casing with specially designed flow passage permit big particles passing without broken.

This series is specially designed for the applications where heavy abrasive slurries exist and the particles are required to keep unbroken during pumping, e.g transportation of pellets in mineral processing.

WG(H) - Gravel & Dredge Pump

WG(H) pumps are designed for continuous pumping of highly abrasive slurries, that containing large particles which series can not handle. Large veins inside the casing make it the best choice for gravel, dredging and other applications where large particles needed to be handled, especially for big flow, high concentration, high head medium. Low NPSH requirement and robust design ensures long life under severe duties.

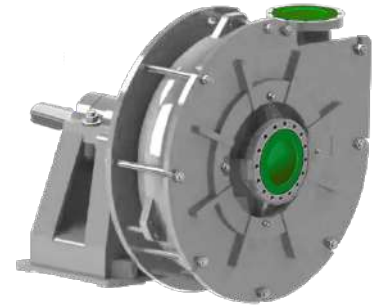

Discharge size: 4"~20" / Capacities to: 5600m³/hr / Heads to: 78m

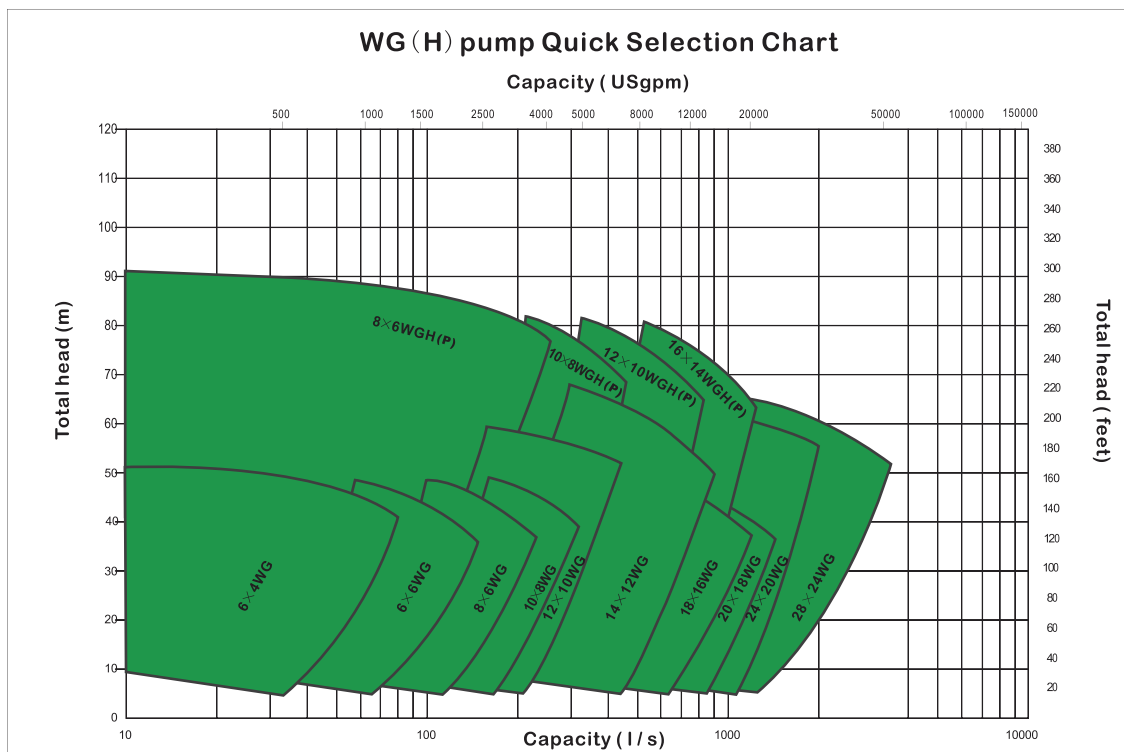

Pump Features

Single stage, single suction, overhang shaft, centrifugal, single casing horizontal pump

Material:

Casing, impeller, plates are made of high-chrome alloy, to resist wear, corrosion and impact.

Bearing Assembly - Grease lubrication and oil lubrication are optional depending on the usage.

Seal options - Gland seal, expeller(centrifugal or dynamic) seal and mechanical seal are optional to fit different application.

Parts design:

Wet parts- Wide internal passage allow large particle to pass un-obstructed, through and reduces wear.

Impeller -Wide passage and recessed vanes, help to lower internal velocity to extend wear life.

Belt joint-Discharge could be any angle. Excellent NPSH performance.

SP Series (Slurry Pumps)

WSH - Heavy Duty Slurry Pump

WSH series pumps are designed for the most difficult pumping applications like highly abrasive and high density situation. They can handle slurries containing excess of 70% by weight.

Combined with advanced hydraulic design, the pumps provide higher efficiency, more wear-resistant volute and impeller, and require less maintenance.



Discharge size: 2"X1.5"~30"X28" / Capacities to: 10000m³/hr / Heads to: 60m

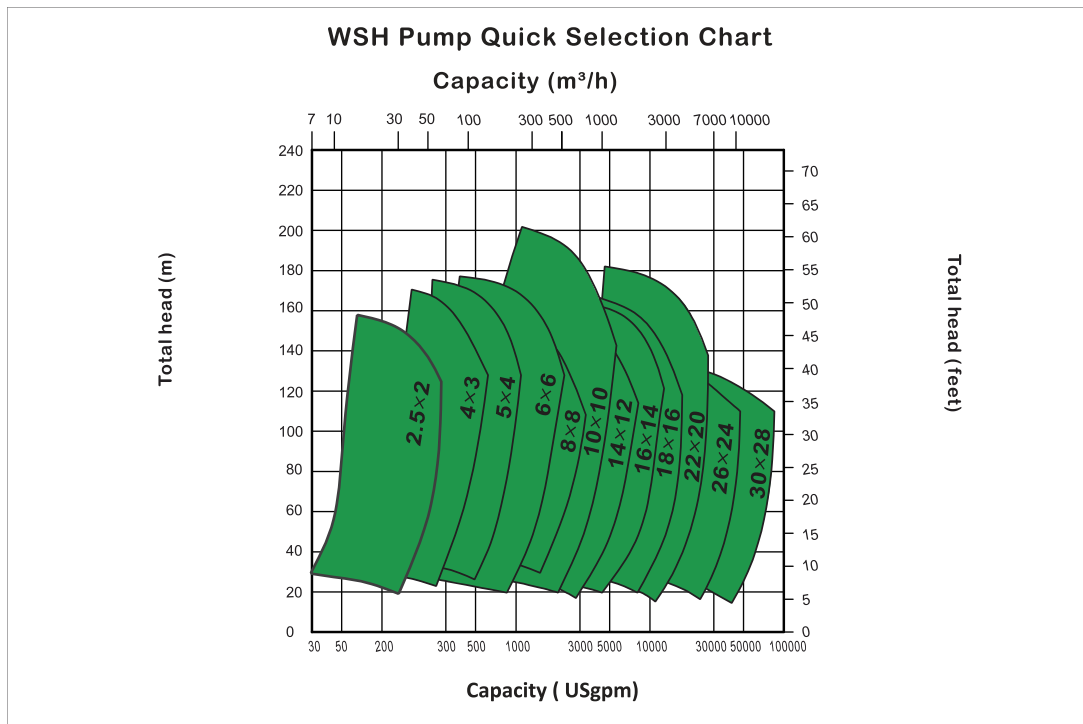

Pump Features

Single stage, single suction, overhang shaft, centrifugal, double casing horizontal pump.

Material

Casing-Made of ductile Iron, with ribs that help casing withstand higher operating pressures.

Wet Ends-Impellers, liners, volutes are made of high-chrome alloy to resist wear, corrosion or impact.

Structure

- Special structure design to fit in high head applications, where more than one pump in series is needed.

High efficiency, lower power draw.

- Oil lubrication to lower bearing temperature, reduced time.

- Impellers are designed to be trimmed multiple times to fit motor speed, when required.

Seal: Expeller + packing seal or mechanical seal are optional and suited to the application

WXF (R)/WLF (R) & WAF - Froth Pump

The WXF(R)/WL(R) & WAF Froth Pumps are designed to economically handle heavy air loaded pulp mixes. This unique foam pumping design includes an enlarged suction diameter and a unique semi-open impeller to facilitate the flow of foam into the pump.

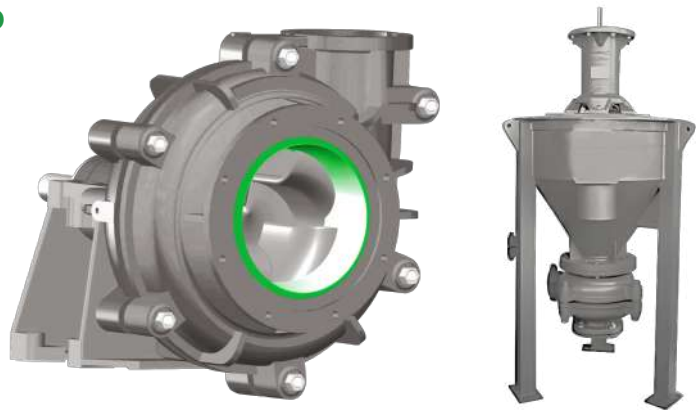

Discharge size: 2"(50mm)~450mm / Capacities to: 5000m³/hr / Heads to: 65m

Discharge size: 2"- 8" / Capacities to: 650m³/hr / Heads to: 30m

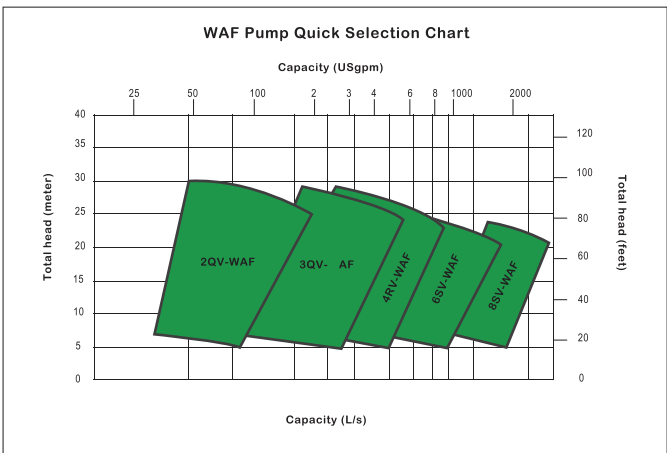
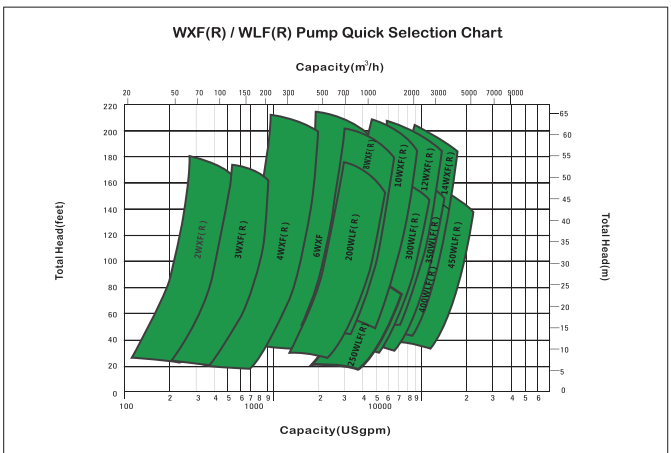

Pump Features

WXF(R)/WLF(R)-Single stage, single suction, overhang shaft, centrifugal, double casing horizontal pump.

WAF-Single stage, single suction, overhang shaft, centrifugal, double casing vertical pump.

Material: Hard metal impellers and elastomer molded/hard metal liners are used to handle corrosive/abrasive froth slurries.

Structure:

-The enlarged inlet of throat bush reduces NPSHr(only for WXF(R)/WLF(R)).

-The blade shape of open impeller and venting pipe in suction pipe help to get as more as froth or viscous slurries into the pump, minimize the pump size and increase efficiency.

-Venting pipe helps to relief air from system, promotes the movement of the froth slurry into the impeller eye.

Seals for WXF(R)/WLF(R)- 3 seal methods are optional:

Gland seal, gland seal with venting system, and Mechanical seal.

(When froth factor is over 1.8, we adopt gland seal with venting system to help release air from the pump.)

Seals for WAF-Don't need any shaft seal or seal water.

SP Series (Slurry Pumps)

WDL (R) - Fuel & Gas Desulfurization Slurry Pump

WDL(R) series pumps are especially designed for fuel and gas desulfurization application for power plants. Mainly applied in absorbing tower circling pump for spray FGD device. Specially designed compact frame can save space for pump installation.



Discharge size: 300~1000mm / Capacities to: 15000m³/hr / Heads to: 35m

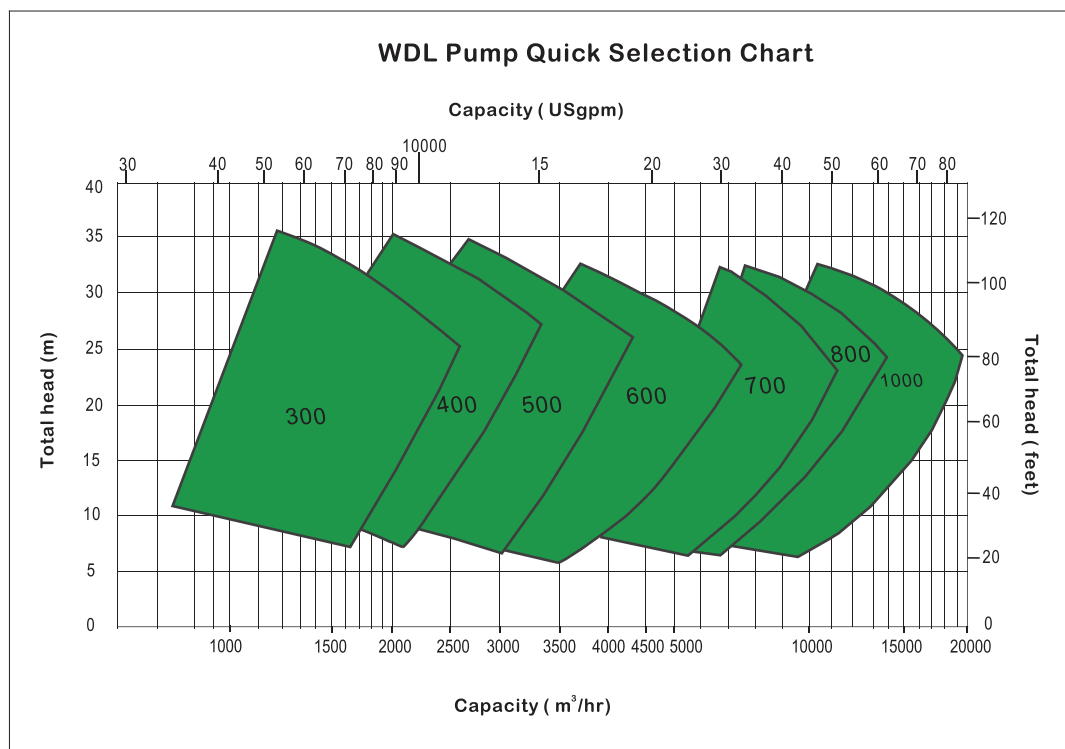

Pump Features

Single stage, single suction, overhang, double casing centrifugal pump

Smaller size (discharge outlet diameter up to 500mm)

Material:

Wet parts--high abrasion and corrosion resistant metal material

Lower frame design ensure pump running in a more secure condition.

Bearing Assembly - cylindrical bearing assembly with grease lubrication

Larger size (discharge outlet diameter 600mm and above)

Material

Metal impeller with rubber liner with high abrasion, corrosion resistant.

Rear demounted structure--Convenient for inspection or change of impeller and mechanical seal without demount inlet-outlet pipeline.

Bearing assembly--Oil lubrication improves bearing life time.

SPS - Submerged Slurry Pump

The SPS pumps are designed for corrosive applications, with solid particles, like mining, power plant, coal, especially handle corrosive slurry with crystals and de-watering.

Suitable for corrosive applications with solid particles, like mining, power plant, coal, especially handle corrosive slurry with crystals and de-watering.



Discharge size: 65~200mm / Capacities to: 700m³/hr / Heads to: 45m

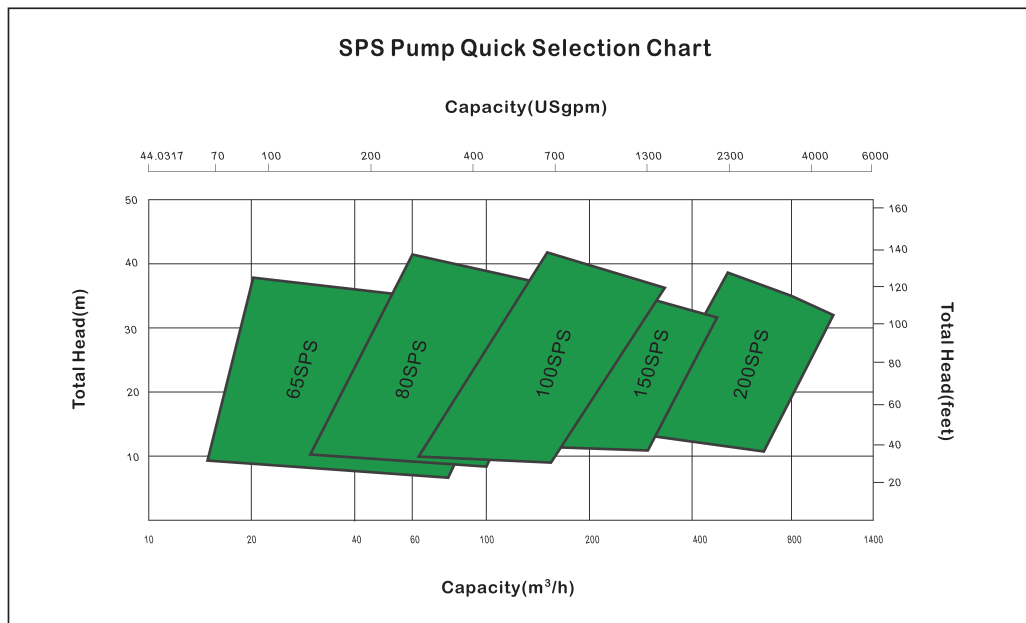

Pump Features

Structure:

- Single stage, single suction, single casing, submerged over-hanging shaft, centrifugal submersible slurry pump.
- Pump and motor are a one-piece unit. Impeller and motor share the same shaft, to ensure stable and smooth operation.
- No shaft seal needed, reduces downtime.
- The unit works submersed; no priming needed.
- No need for external protection (self-guarded) and is loose fitted and could be moved to the required place, conveniently
- Less noise and vibration.

Material:

- Wet parts are made of high-chrome alloy to resist wear, corrosion or impact and reduces cost of ownership.

SP Series (Slurry Pumps)

SPH & SPL - Medium to Heavy Duty High Head Slurry Pump

These hard metal slurry pumps are designed for high head applications. Oil lubrication with water-cooling temperature thus shaft could rotate more rapidly to get high head, direct connected drive are always optional by trimming impeller to appropriate diameter and to get performance just in need, save the cost of variable-frequency motor. Specially designed liners and impellers structure help pump get higher efficiency and high head.

The pumps can be used in sea water handling applications after specialim-provement, and can be used in series under 3.6MPa

SPH is widely used in mining tailing transportation applications, while SPL is widely used in coal preparation applications.



Discharge size: 40~300mm / Capacities to: 2333m³/hr / Heads to: 128m

Discharge size: 65~300mm / Capacities to: 1920m³/hr / Heads to: 94m

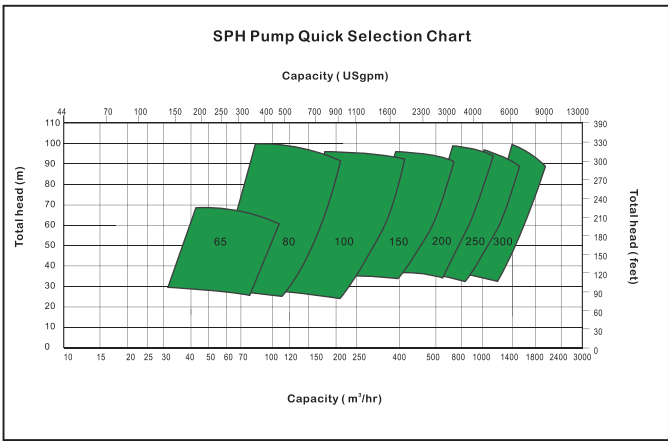
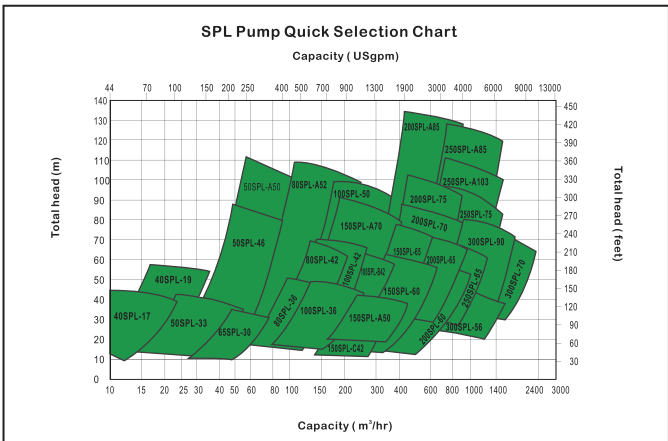

Pump Features

Single stage, single suction, overhang shaft, centrifugal, double casing horizontal pump.

Material

Casing-Made of ductile Iron, ribs help casing to stand high pressure.

Wet Ends-Impellers, liners, volutes are made of high-chrome alloy or ceramics to resist wear, corrosion, shock or brush

Structure

-Special structure design to fit in high head applications where more than one pump in series are needed.

High efficiency, lower power cost.

-Oil lubrication to lower bearing temperature, reduce down time.

-Impellers are designed to be trimmed multiple times to fit motor speed, coupling connection between pump and motor help pump running more stable and reliable.

Seal

Expeller + packing seal and mechanical seal are optional, to reduce leakage risk.

WXS - Heavy Duty Non - clogging Pump

WXS non-clogging pumps are designed for continuous slurry handling applications for larger or breakage sensitive particles. This range of vortex pumps are capable of handling large as well as very soft particles. The large volume internal profiles, combined with the recessed open impeller design, reduce particle interaction and limit potential blockages.



Discharge size: 2~8 / Capacities to: 500m³/hr / Heads to: 42m

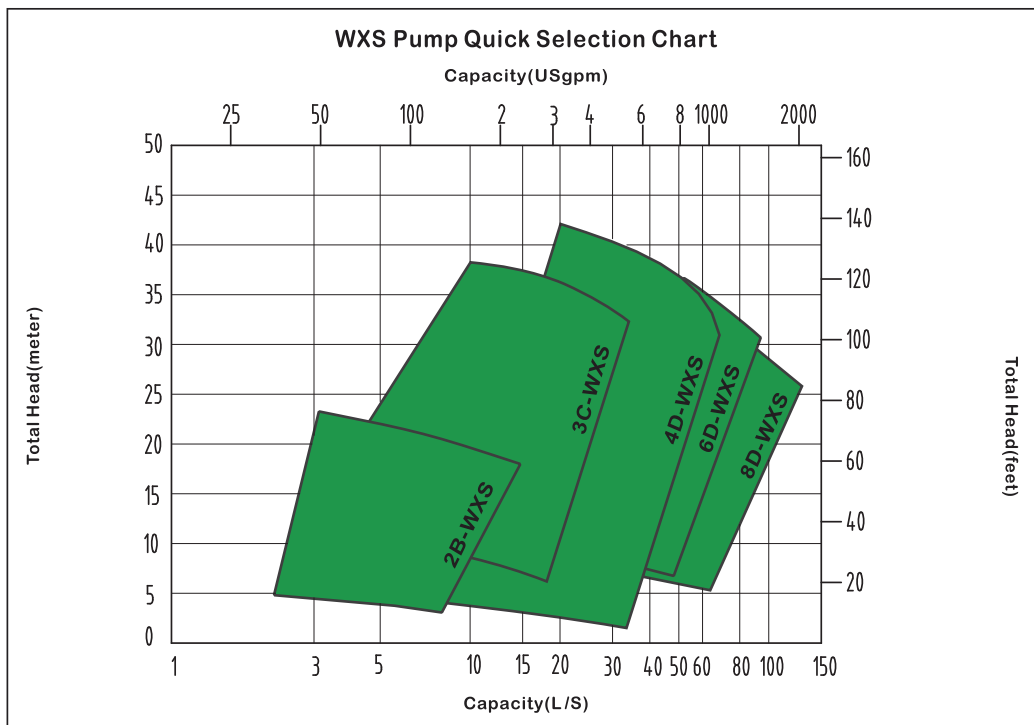

Pump Features

Single stage, single suction, overhang shaft, centrifugal, single casing horizontal pump

Material

Casings, impellers, liners are made of high-chrome alloy to resist wear, corrosion and impact.

Bearin assembly - Grease lubrication is optional depending on the usage.

Parts design:

Recessed impeller and the large volume casing have allowed the impeller vanes to be positioned outside of the general flowpath of the fluid. The pump has large particle handling capability as well as very low particle degradation due to the limited vane interaction with the medium being pumped.



CORVEX
P u m p s
www.corvexpumps.com



Sales Enquiries: info@corvexpumps.com